

Circulator
Howard Olson, Editor
W14441 State Hwy 29
Bowler, WI 54416

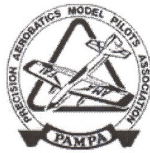

Circlemasters Circulator

Newsletter of the Circlemasters Flying Club
Milwaukee Wisconsin
Academy of Model Aeronautics Chartered Club # 662
November 2015 Volume 12 issue 11

At The Handle

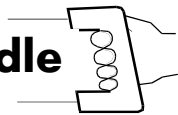

If you would like to contribute material, please submit to the address on the cover or contact me at (715) 697-8458 I may be reached via e-mail at clmodman@wctc.net

Ramblings from your Editor

Ready or not, here it comes! The *Circulator* is back for another round. Not a ton of controlling going on around here these days. Things at Circle Masters outpost North has shifted into winter survival preparation mode, which comes right before building season. I will try to drum up some things to keep you occupied for a few minutes.

Have you looked at ebay lately? There is an interesting trend going on over at the electronic auction house. For years, prices have been down, relatively speaking, on most items to tempt the ukie enthusiast. Now what I have been seeing is going a whole different direction. Prices that sellers are asking for model airplane goodies are way up, sometimes ridiculously so. Funny thing is, nobody is buying them. I have a theory about what is happening here. It appears as though the merchants are not real toy airplane peeps. Some of these nuts seem to have no concept of the value of their items! How about a Testor's Fly'em Bf-109 with missing parts offered for over two hundred dollars? Whoop eee! This is obviously someone who thinks all model airplane pieces are priceless collector's items. This is just one example of many such fantasies on the bay. Prices are up on some legit collectable or otherwise desirable engines, kits, etc. but there is a profusion of these far out cases. I am beginning to wonder if some are scammers testing the waters on how gullible the buying public is. Anything is possible on the web.

Here's one to warm your heart. Everybody's favorite *Name That Plane* is back for the off season. Remember these few simple rules: First, you must be present to win. If you aren't at the meeting, you are a complete loser, even if you have the correct solution. Secondly, some aircraft may have more than one name. The answer you give must match my answer, unless you can give me irrefutable proof that yours is valid. You have to have the buck stop somewhere. And finally most importantly, Big How makes the rules, resolves the disputes and all that malarkey, so give it your best shot. I try to make it challenging, but doable, if you give it some effort. As usual, winners get majesty and fabulous prizes.

This next item is important, so listen up. We need something to use for the entertainment portion of the November meeting. Please bring a video or do an awe inspiring demo to keep the natives from getting restless. Remember, the club is only as good as the members are willing to make it. If the meetings aren't enjoyable, there is little reason to do this, so make an effort to contribute to the common good. Wow, that sounded almost socialist. After the meeting, consider applying for a concealed carry permit and write to your congressman about federal budget reform. Ok, now I feel better.

In my ongoing futile attempt to get you guys to build scale models, I have another complete set of scale documentation. One of these times it has to work. There's a page full of pictures from the September meeting in there someplace too.

That's it, I can't be at the meeting because of my work schedule. If that situation changes, I will show up. The Mrs. should be in attendance and will officiate the Name the Plane contest in my absence. See you in December and have a lovely Thanksgiving, we have a lot to be thankful for in the country where even our poor people are fat and a flat screen TV is considered a necessity.

Signing off,

Howard



CIRCLE MASTERS FLYING CLUB
MEETING MINUTES for OCTOBER 2015

The monthly meeting of the Circle Masters Flying Club for September was held at the Sussex Library due to absurd weather conditions which cancelled flying activities.

The meeting was brought to order by Pres. Greg at 1:00 PM. There were ten members present and the minutes of the September meeting were approved. In addition, the club treasurer's report was approved.

REPORTS & ANNOUNCEMENTS:

Treasurer Ralph announced that he will begin accepting club dues (\$20.00) for 2016.

Wayne reported that the club sign has been completed. The remaining portion which included Dan's picture along with a brief description has been installed. Dave will take a picture of the completed sign and post it on the club web site.

OLD BUSINESS: Greg indicated the long awaited pamphlet showcasing the club and its activities has been completed and copies will be available at the November meeting.

NEW BUSINESS:

Pete began a discussion about dates for the 2016 club contest. June 5th or the 12th seem to be the best options. Location availability must be confirmed first; Mike will check into this. Pete will check other contests for any conflicting dates. A final decision will be made at an upcoming meeting.

There being no further business Greg call for adjournment of the meeting at 1:45 PM. A motion was made and seconded to adjourn the meeting.

SHOW & TELL: Mike brought a newly constructed stunt version of a Grumman Hellcat. Electric powered of course.

Submitted by: Wayne M. Schmidt, Secretary

10/22/2015

Upcoming Events 2015 Is winding down folks

November meeting: Saturday November 7th, Pauline Haass Public Library N64 W23820 Main St, Sussex, WI. Meeting at 1:00PM Entertainment of some kind at 12:00 noon.

December Meeting: Saturday December 5th, Pauline Haass Public Library N64 W23820 Main St, Sussex, WI. Meeting at 1:00PM annual Christmas Party begins at 12:00 noon.

January Meeting: Saturday January 2nd, Pauline Haass Public Library N64 W23820 Main St, Sussex, WI. Meeting at 1:00PM Entertainment and Fellowship at 12:00 noon.

So far I have been unable to find any info for a 2016 swap meet at the Waukesha Expo. The Happy Hobby web site does not show anything. Maybe someone can find out about this before the meeting.

Name That Plane



Ok, we will start you off easy peasy lemon squeezy. This bird might seem obvious., but you know Big How likes to mess with your head, so be careful.

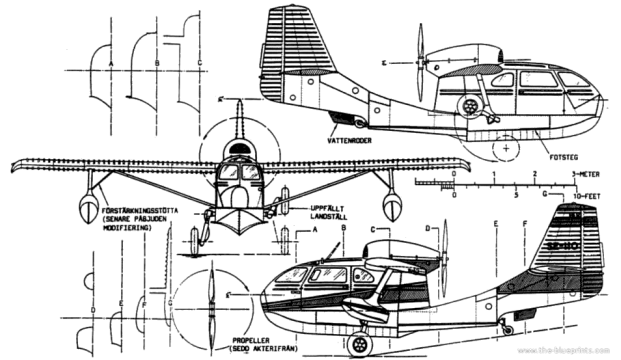
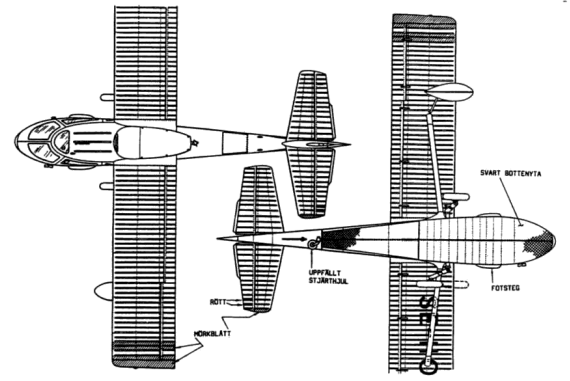

September Highlights 2015



Hiawatha Hobbies

**Silvernail Shopping Center
2026 Silvernail Road
Pewaukee, WI 53072
262-544-4131**

ELIMINATOR PROPS

Steve Wilk
3257 Welcome Avenue North
Crystal MN 55422
763-531-0604
swilk@cpinternet.com
Carbon and fiberglass props and accessories
for all types of competition model airplanes

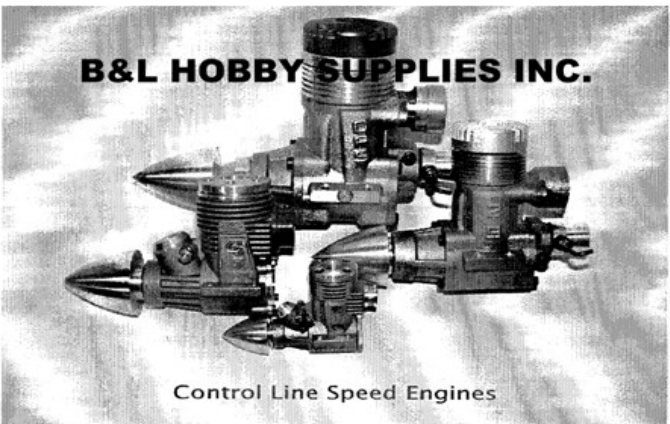

B&L HOBBY SUPPLIES INC.

Control Line Speed Engines

- CS and GZ from China and now OPS Engines from Italy
- B & L is now the Distributor for John Newton Products
- Fiberglass Speed Model parts and Aluminum Wings

For more information, please phone, e-mail or send a SASE:

Bill Hughes
113 N. Chase Avenue
Bartlett, IL 60103
Phone - 630.736.6036
e-mail - williamhughes4@comcast.net



7125 N. 76th Street
Milwaukee WI 53223
414-461-6013

MBS MODEL SUPPLY

Melvin Schutte
P O Box 282
Auburn KS 66402 785-256-2583

Lines: solid and braided
Nelson glow plugs Many other items for
the C/L enthusiast